

## UNIT 3 TEST

[9] 1. For each relation below, state whether it is a function and its domain and range.

a)  $\{(1, 9), (2, 7), (3, 5), (4, 3)\}$

Function (Y/N): \_\_\_\_\_

Domain: \_\_\_\_\_

Range: \_\_\_\_\_

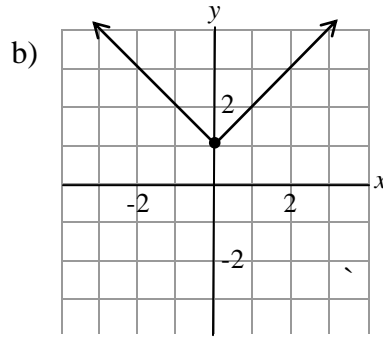

Function (Y/N): \_\_\_\_\_

Domain: \_\_\_\_\_

Range: \_\_\_\_\_

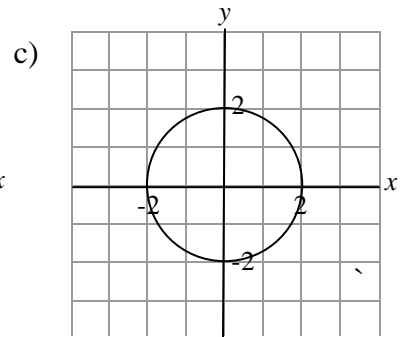

Function (Y/N): \_\_\_\_\_

Domain: \_\_\_\_\_

Range: \_\_\_\_\_

[5] 2. If  $f(x) = 3 - 2x$ , find:

a)  $f(1)$

b)  $f(3a - 1)$

c)  $x$  when  $f(x) = -7$

[4] 3. For each function below, find its inverse  $f^{-1}(x)$ . Show your work.

a)  $f(x) = \frac{2x - 5}{7}$

b)  $f(x) = 1 + \sqrt{x + 2}$

[4] 4. Sketch the inverses of the following functions on the same grids they are drawn.

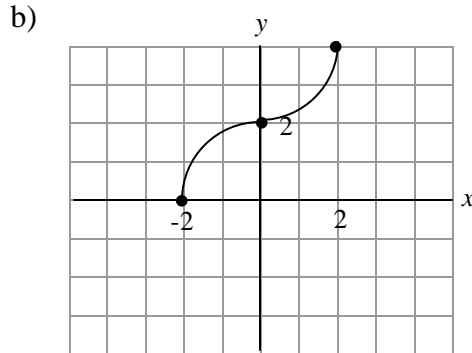
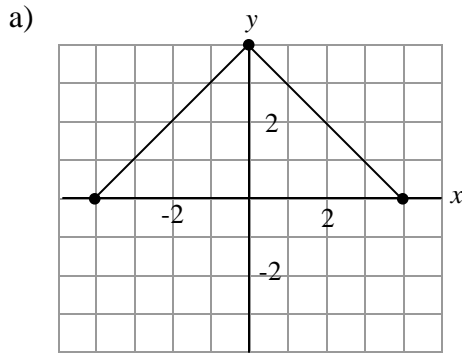

[10] 5. Given  $f(x) = \sqrt{x} - 3$ ,

a) Write equations for:

$-f(x) =$  \_\_\_\_\_

$f(-x) =$  \_\_\_\_\_

c) Determine any points that are invariant for each reflection.

$-f(x) :$  \_\_\_\_\_

$f(-x) :$  \_\_\_\_\_

b) Sketch all three graphs on the same set of axes. Label each curve.

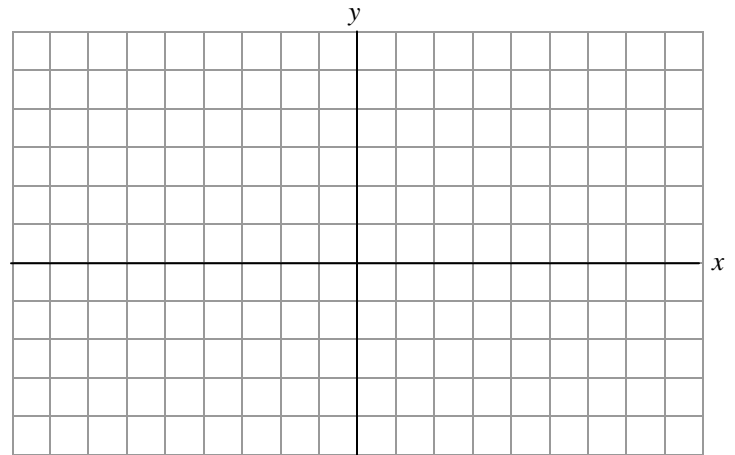

d) State the domain and range for all three functions.

$f(x) :$

D: \_\_\_\_\_

R: \_\_\_\_\_

$-f(x) :$

D: \_\_\_\_\_

R: \_\_\_\_\_

$f(-x) :$

D: \_\_\_\_\_

R: \_\_\_\_\_

[9] 6. For each function below, list the transformations, in the order you would apply them from the graph of  $y = f(x)$ .

a)  $y = f(x - 2) - 3$

b)  $y = -f(2x)$

c)  $y = \frac{1}{3}f(x + 9)$

d)  $y = f(-\frac{1}{5}x) + 7$

[5] 7. The graph of  $f(x) = \sqrt{x}$  is stretched vertically by factor 3, reflected in the y-axis, and then translated 2 units down.

a) Sketch the graph of the base curve and each individual transformation. Label your final curve.

b) Write the equation of the new function.

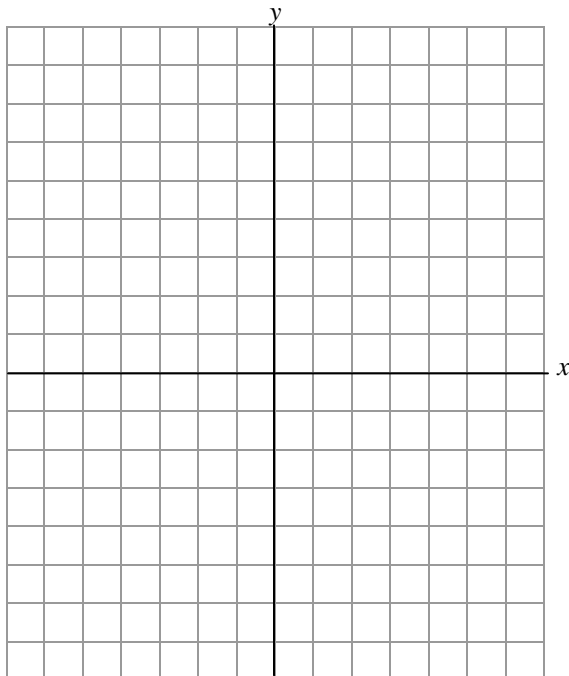

[10] 8. a) List the transformations, in the order you would apply them for the graph of  $y = f(x)$  to the graph of  $y = -2f(2(x-4))+3$ .

b) Start with the graph of the base curve,  $f(x) = x^2$  provided and sketch each individual transformation. Label your final curve.

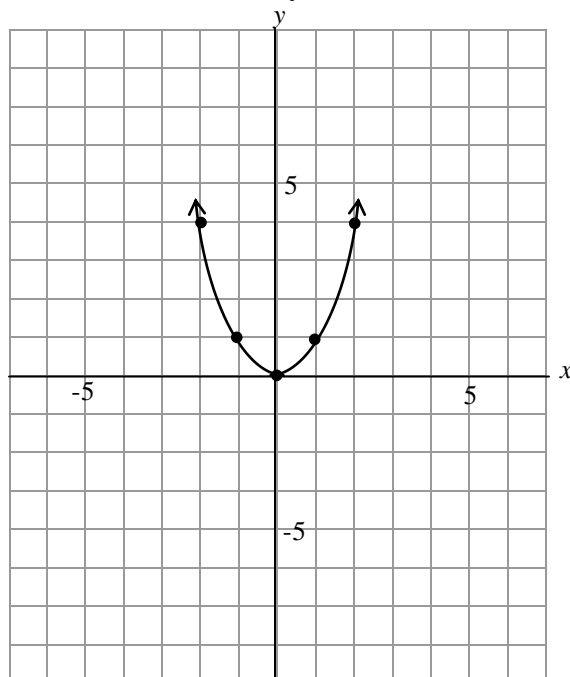

[5] 9. A manufacturing company produces garage doors. The number of garage doors,  $g$ , produced per week is related to the number of hours of labour,  $h$ , required per week to produce them by the function  $g(h) = 1.8\sqrt{h}$ .

a) How many doors can be produced per week using 500 hours of labour?

b) Determine the inverse of the function.

c) Explain its meaning (i.e. what it can be used to calculate).

d) How many hours of labour are needed each week to keep production at or above 25 doors a week?

### **BONUS**

---

[2] 10. Consider the exponential function  $f(x) = 2^x$ .

a) What point is invariant when it is reflected in the y-axis?

b) What is the equation of the horizontal asymptote of the transformed function  $y = f(x) - 5$ ?

[1] 11. Write the equation of a function that is its own inverse.